

Linearity Verification of Microwave Receivers Using a Precision Power Meter

Problems With Broadband Linearity Testing

The linearity of an RF or microwave receiver is typically measured at its intermediate frequency. Nonlinearities at high signal levels due to mixer compression, and at low levels due to noise, are then specified as maximum error figures. However, finding accurate, affordable instruments for direct microwave power measurements could be a problem

Scope and Purpose of App Note

This application note shows how linearity can be measured over a frequency range of 100kHz to 40GHz using a precision power meter and a few power standards. Specifically, it covers use of the TEGAM Model 1806 Dual Type IV Power Meter (Figure 1) and Models 1110, 1111, 1118 and 1120 Temperature Controlled Power Standards (Figure 2).

Ancillary equipment is also described, along with accuracy considerations. Using the recommended equipment, the app note describes linearity verification techniques that result in measurement uncertainty of less than 0.005dB/10dB step. A TEGAM Model 8850 receiver is used to demonstrate these results.



FIGURE 1. MODEL 1806 DUAL TYPE IV POWER METER

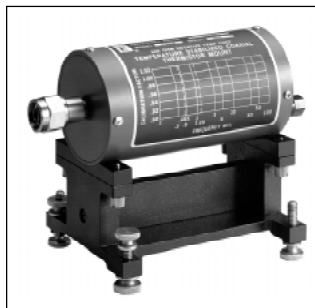

FIGURE 2. MODEL 1110

Measurement Theory

The basic technique for linearity measurement, described later in detail, is to use the TEGAM Model 1806 Power Meter to transfer NIST calibration factors to the receiver via TEGAM's feedthrough power standards. This precludes the need to make direct microwave measurements at the frequencies of interest.

Power Meter Principles — The bridge technique used in the Model 1806 (Figure 3) was developed by NIST and works on the principle of DC power substitution (References 1 and 2). The thermistor mount power standards such as the Models 1110, 1111, 1118, and 1120 can be connected to any Type IV Power Meter without change of calibration factor. The calibration factors of diode and thermocouple power sensors depend on the power meters to which they are attached and cannot serve as independent standards (Reference 4).

Figure 3 shows a schematic representing the operation of the Type IV Bridge and Thermistor Mount. The two 100 Ω thermistor beads in the mount are in parallel to incident RF power, and in series to DC. This gives an RF input impedance of 50 Ω , and a DC resistance of 200 Ω . Being thermistors, these values are only reached when the temperature of the beads reaches a certain point. In this bridge arrangement, this point is reached by a combination of placing the beads in a temperature controlled oven and passing a certain DC current through them. The current is generated by making the series combination of thermistor beads an arm of a self-balancing bridge.

The same current flows through the thermistor pair and the precision 200 Ω resistor. The bridge circuit adjusts this current until the voltages across the resistor and the thermistor pair are equal. Then the DC power to and the resistance of the thermistors are equal to the DC power to and resistance of the precision 200 Ω resistor. Thus the DC power dissipated in the thermistors can be determined from measurements of the DC voltage across the precision 200 Ω resistor (typically with a high precision digital voltmeter (DVM)). Thus the DC power dissipated in the thermistors can be determined from measurements of the DC voltage across the precision resistor.

The thermistors are adjusted in production to have 200 Ω with about 30 mW of DC power applied. This gives about 2.45 volts across the thermistor pair. When RF power is applied, the

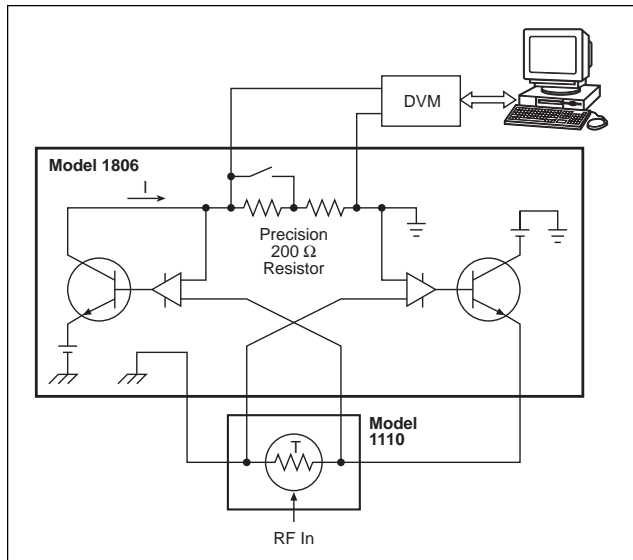

FIGURE 3. PRECISION POWER MEASUREMENT SYSTEM SCHEMATIC

bridge reduces the DC power to keep the thermistor pair resistance at 200 Ω. The change in DC power is equal to the applied RF power times the calibration factor provided by NIST.

Since the type IV bridge and thermistor mounts are ideal for power calibration transfer, they are also useful to measure changes in power. The very technique of substituting power and keeping the beads in a constant state, coupled with the ability to accurately measure resistors and voltage at DC, removes a large amount of uncertainty in the measurements. The frequency related calibration factor drops out of the measurements to the extent that it is not level related. Traceability is through the DC calibration of the DVM. Signal reflection is not a factor if it is constant during a measurement.

Linearity Measurements — Receiver linearity can be measured by simultaneously measuring a signal attenuation step by the receiver and the precision power meter. The bridge measures the attenuation step by determining DC power to the thermistors with no RF power applied, P_{OFF} , with the attenuator in one position, P_{SUB1} , and with the attenuator in the other position, P_{SUB2} . These powers are determined by squaring the DC voltages measured across the precision resistor in each case and dividing by 200 Ω. The first RF power level is then:

$$\frac{(P_{OFF} - P_{SUB1})}{K}$$

where K is the calibration factor of the power standard at the RF frequency. The second power level is given by:

$$\frac{(P_{OFF} - P_{SUB2})}{K}$$

The attenuation or the power ratio in dB then is:

$$10 \log \left[\frac{(P_{OFF} - P_{SUB1})}{(P_{OFF} - P_{SUB2})} \right]$$

Note that the calibration factor of the power standard, power reduction due to reflection from the power standard, and the DC resistance of the precision resistor, all drop out of the results.

Linearity Measurement Procedures

Figure 4 shows the measurement setup used for linearity verification. This setup was used to verify the performance of a TEGAM Model 8850 Receiver, consisting of the Model VM-7 and Model 8852 Frequency Converter. (This receiver has a linear region specification of ± 0.005 dB/10 dB.) Results of these verification tests are described later.

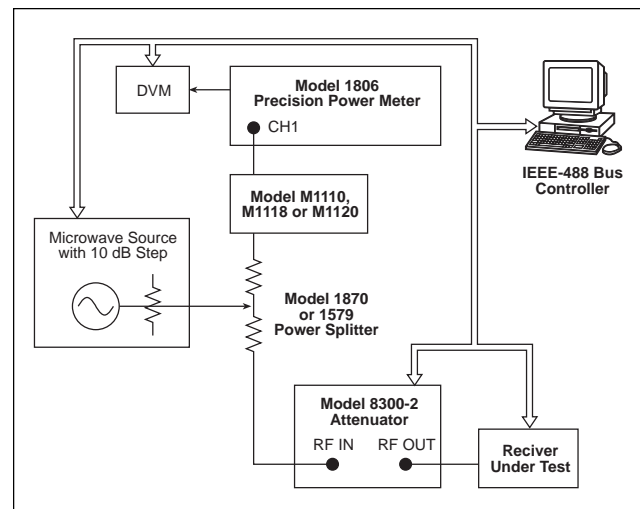

FIGURE 4. RECEIVER LINEARITY VERIFICATION SETUP

Since linearity accuracy is typically specified as dB of error in a 10 dB (or other) step, the signal source's internal attenuator can be used to provide the power step. Its exact value and repeatability are not of primary importance as long as it is nominally 10 dB. As the step switches, it is measured by both the precision power meter (Model 1806) and the receiver. The values are then compared and the difference used to characterize receiver linearity.

The Weinschel Model 8300-2 Level Set Attenuator is used to vary the input level to the receiver. Changes in SWR as the attenuator switches are not important, as there is no change while the 10 dB step is operated and measured.

During measurements of a TEGAM Model 8850 Receiver, using the setup in Figure 4, the levels at the top and bottom of a step typically were 2.337 mW and 234.2 μ W. This yields a nominal step of 9.9907 dB. If an HP 3458A voltmeter is used, the linearity part of its accuracy results in step uncertainty ranging from 9.9902 to 9.9912 dB, i.e. ± 0.0005 dB. (See accuracy discussion below.) Table 1 lists typical results based on a test of the Model 8850 at 1500MHz. The uncertainty in the linearity measured with this setup is less than 0.005dB/10dB step, except for the two lowest power levels.

TABLE 1. TYPICAL LINEARITY RESULTS TAKEN @ 1500 MHz

8300 Setting (dB)	Power Level (dBm) RefPwr	VM7 step	Precision Power Meter	Difference
0	-14.261	9.998	10.007	0.003
5	-19.068	9.997	9.9979	0.000
10	-24.260	10.000	10.0004	0.000
15	-29.095	9.998	9.9996	0.002
20	-34.169	9.999	9.9976	-0.001
25	-39.014	9.999	9.9972	-0.002
30	-44.190	9.999	9.9978	-0.001
35	-49.027	9.998	9.9982	0.000
40	-54.117	9.999	9.9981	-0.001
45	-58.957	9.999	9.9980	-0.001
50	-64.134	9.999	9.9979	-0.001
55	-68.971	10.000	9.9999	-0.000
60	-74.111	9.999	9.9967	-0.002
65	-78.951	9.998	9.9991	0.001
70	-84.129	9.999	9.9985	-0.001
75	-88.970	9.994	9.9984	0.004
80	-94.235	9.999	9.9978	-0.001
85	-99.080	9.992	9.9977	0.006
90	-104.276	9.979	9.9985	0.020

Accuracy Discussion

If the test setup uses a superior performance voltmeter, such as the HP 3458A, the one year accuracy becomes 8 ppm + 0.05 ppm of range. On the 10 V scale, the linearity part of its accuracy becomes 0.0000005V, which translates to an uncertainty of 0.0024% in a 1 mW power substitution measurement. This is a better choice for high accuracy results.

The specifications of the Model 1806 allow substituted power measurements with an accuracy of $\pm 0.003\%$. However, this power is measured using a voltmeter. The addition of a typical voltmeter, such as the Fluke Model 8506A, can increase the measurement uncertainty to $\pm 0.03\% \pm 2 \mu$ W. The Model 8506A has a drift specification over 180 days of 13 ppm + 8 counts. Analysis shows that the 13 ppm translates to an error of ± 0.00011 dB in a power step. The 8 counts, which is a measure of the voltmeter's linearity, translates to an error of 0.4 % in a

1 mW power substitution measurement, and is random in nature. Therefore, voltmeter resolution is the dominant source of error in the measurement of a power step. (Reference 5)

TEGAM power standards, such as the Model 1110, have a specified linearity of $\pm 0.1\%$ from 1 mW to 10 mW. This is equivalent to an uncertainty in a 10 dB step of ± 0.0043 dB. Since the typical step is approximately 2.5 mW at the higher point, the likely uncertainty is probably closer to ± 0.001 dB. Total uncertainty then is on the order of ± 0.0015 dB. (All uncertainty values are Type B, as described in References 6 and 7.)

Overall test system accuracy can be independently verified with the Voltage Doubler technique shown in Figure 5 (Reference 3). In this set-up, terminating power standards are connected to both channels of the Model 1806. One is connected to the output port of the Voltage Doubler, while the other is connected to the reference port. The nominal 6.0206 dB step of the Voltage Doubler can be calibrated by NIST to an uncertainty of less than 0.0001 dB at 1.25 MHz, and close to 0.001 dB at 30 MHz (Reference 8). A 1.25 MHz or 30 MHz signal is used as the test signal. The doubler arms are switched in and out as power is measured with the Model 1806 and DVMs. The second channel merely corrects for changes at the constant voltage point of the doubler. From the two power measurements, the doubler step can be calculated and results compared to that given by NIST.

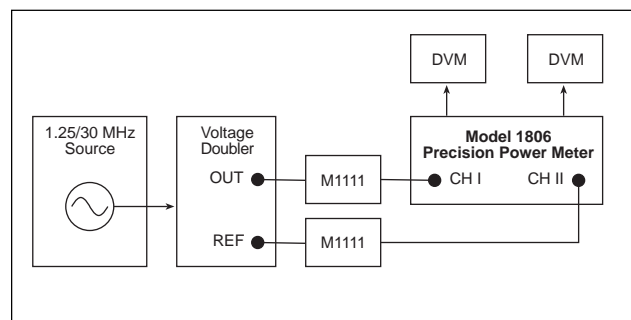

FIGURE 5. PRECISION POWER METER LINEARITY VERIFICATION

Conclusion

Microwave and RF receiver linearity can be determined with an uncertainty of about 0.001 dB/10dB step in the frequency range from 100 kHz to 26.5 GHz by using the TEGAM Model 1806 Dual Type IV Power Meter along with a TEGAM Model 1110, 1111, 1118 or 1120 Power Standard, which function as a precision power ratio measurement system. The technique can be extended to 40 GHz using the TEGAM Model 1107-8 Waveguide Standard.

References

1. "A Self Balancing Direct-Current Bridge for Accurate Bolometric Power Measurements," G.F. Engen, J. Res, NBS, Vol. 59, 1957, pp. 101-105.
2. "A New Self-Balancing DC-substitution R.F. Power Meter," N.T. Larsen, IEEE Trans. on Instrumentation and Measurement, Vol. IM-25, No. 4, pp. 343-347, December 1976
3. "A Voltage Doubling Circuit for the Absolute Calibration of 30 MHz Attenuation Measurement Systems," P.I. Somlo, IEEE Transactions on Instrumentation and Measurement, Vol. IM-27, No. 1, March 1978, pp. 76-79.
4. "Techniques Explained for CW Power Measurement," B.O. TEGAM, et. al., MSN & CT, May 1986, pp. 78-102.
5. System IIA, Automatic Power Meter Calibration System," Manual IM-198, from TEGAM, Section 3-10.
6. "Guide to the Expression of Uncertainty in Measurement," ISO/TAG4/WG3:
7. "Guide for Evaluating and Expressing the Uncertainty of NIST Measurement Results," NIST Technical Note 1297.
8. "The NIST 30 MHz Linear Measurement System," Journal of Research of the National Institute of Standards and Technology, Volume 99, Number 1, January-February 1994, p. 19.

